

GREAT WALL CLADDING INSTALLATION INSTRUCTIONS

(Wooden Joist Vertical installation)

FLLLOW

Great Wall cladding installation instructions (Wooden joist Vertical installation)

Key points:

Please read this wall cladding installation instructions carefully before the wall cladding construction and installation.

Caution:

The installation diagrams and instructions described in this guide are for installation purposes only. Any use of Honorwood product profiles must comply with relevant local laws, regulations and building codes. The user assumes all risks and responsibilities associated with such use.

Installation using tools:

Standard woodworking tools, such as chainsaws (desktop and portable), impact drills, hand drills, etc. Our common saw blades are diamond saw blades.

Installation work protection:

Operators should be safety conscious, use safe and qualified construction equipment and wear appropriate protective tools, such as cut-resistant gloves, dust masks, etc.

Profile application structure:

Honorwood product profiles cannot be used alone for other load-bearing structures such as beams and columns, and must be used in conjunction with some of the profiles available for load-bearing structures.

Construction and installation drawings:

Before using Honorwood product profiles, the corresponding drawings should be made according to the site to ensure the reasonable matching and dimensional accuracy of the profiles, as well as to reduce unnecessary material loss and labor idleness during construction.

Product storage environment:

Honorwood products must be stacked on a flat, level hardened ground, and avoid direct contact between the product and the ground and long-term in a wet, waterlogged area. To reduce the deformation caused by the product, etc.

Product environmental adaptation:

Honorwood products in the local installation before construction, need to be stored in the local environment for 48 hours to stabilize the product thermal expansion and contraction before use, in order to avoid the large temperature difference between the two places caused by the accuracy of the paving.

Board installation basis:

The Honorwood wall cladding installation cannot be fixed directly on the substrate surface, joist is needed to ensure that the rain water inside the wall cladding drains smoothly and stays dry. The distance between the wall cladding and the substrate surface is 50 mm.

Caution:

Honorwood wall cladding when you need to use the nail fixed, must first play a good pre-drilled holes, pre-drilled holes can not be smaller than the screw rod diameter of more than 1 mm. Open nail parts from all the edges of the wall cladding must not be less than 10 mm.

Great Wall cladding installation instructions (Wooden joist vertical installation)

Wood plastic products surface temperature and product thermal expansion coefficient, i.e., length of the guide parameters of the gap (mm) table





Product length (m)	Installation Temperature of the product surface /°C Applicable to ambient temperatures, resulting in plate temperatures between -10~60°C Between, allowable deviation ±5°C														
	-10	-5	0	5	10	15	20	25	30	35	40	45	50	55	60
0.5	1.5	1.3	1.3	1.2	1.1	0.9	0.8	0.8	0.7	0.5	0.4	0.3	0.3	0.1	0.0
1	2.9	2.8	2.5	2.4	2.1	1.9	1.7	1.5	1.3	1.1	0.8	0.7	0.4	0.3	0.0
1.5	4.5	4.1	3.8	3.4	3.2	2.9	2.5	2.2	1.9	1.6	1.3	0.9	0.7	0.3	0.0
2	5.9	5.5	5.0	4.6	4.2	3.8	3.4	2.9	2.5	2.1	1.7	1.3	0.8	0.4	0.0
2.5	7.4	6.8	6.3	5.8	5.3	4.7	4.2	3.7	3.2	2.6	2.1	1.6	1.1	0.5	0.0
3	8.8	8.2	7.6	7.0	6.3	5.7	5.0	4.5	3.8	3.2	2.5	1.9	1.3	0.7	0.0
3.5	10.3	9.6	8.8	8.1	7.4	6.6	5.9	5.1	4.5	3.7	2.9	2.2	1.5	0.8	0.0
4	11.8	10.9	10.1	9.2	8.4	7.6	6.7	5.9	5.0	4.2	3.4	2.5	1.7	0.8	0.0
4.5	13.3	12.3	11.3	10.4	9.5	8.5	7.6	6.6	5.7	4.7	3.8	2.9	1.9	0.9	0.0
5	14.7	13.7	12.6	11.6	10.5	9.5	8.4	7.4	6.3	5.3	4.2	3.2	2.1	1.1	0.0
5.5	16.2	15.0	13.9	12.7	11.6	10.4	9.2	8.1	7.0	5.8	4.6	3.4	2.4	1.2	0.0
6	17.6	16.4	15.1	13.9	12.6	11.3	10.1	8.8	7.6	6.3	5.0	3.8	2.5	1.3	0.0

Additional Notes:



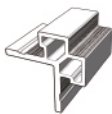

- The above table, calculated based on the linear expansion coefficient of the material tested by a third party, is a reference guide of approximately 0.042mm of expansion or contraction of the length of the sheet per 1 meter of sheet, for every 1°C rise or fall.
- The temperature in the above table refers specifically to the surface temperature of the product (sheet), not the ambient temperature. It is recommended to use a handheld "infrared thermometer" to measure it. The above table of "gap" parameter refers to the lengthwise, straight line distance between two product (sheet) ends.
- Products (boards) that require direct screw fixing in individual areas must be pre-drilled and then screwed.
- Connection parts for fixing wall claddings, one part fixing cannot be bigger than 2 wall claddings.
- If there is more than one wall cladding laid in the length direction of the wall cladding, the wall cladding joints are sealed with HLYC-013F edging version, and the wall cladding is reserved with a gap in the HLYC-013F groove, with the gap referring to the linear thermal expansion coefficient.
- Case in point:
Such as the selection of 3.5m / root of the board installation, the installation of the board surface temperature measured at 16 °C, and the local year-round climate characteristics, the highest temperature of the assessment of the board 60 °C (allowed ± 5 °C); such cases, from the above table can be found, the installation, the length of the board direction, adjacent ports, should be reserved for 5.9-6.6 mm spacing.
- Special climate reference: the above table only lists the highest to the product (board) surface temperature of 60 (±5°C), basically can be universal most of the use of the environment. If the actual environment is more special, reasonable installation joints can be made according to the guideline of "for every 1 meter of sheet, the length of the sheet expands or contracts by about 0.042mm for every 1°C rise or fall".
- General description: The linear expansion coefficient of our profile (board), in line with the requirements of European standards, American standards, and this coefficient guide the installation of seam. But the linear expansion coefficient is only for the profile (board) is not installed fixed free state, temperature on the length of the profile (board) shrinkage and expansion, and can not cover all the actual use of environmental elements. In response, I hereby add: If the user has a reasonable installation case of WPC products with HDPE as the main raw material, and there is no quality risk caused by shrinkage and expansion after long-term verification, and the installation case is different from the above comparison table provided by our company, in this case, the user can follow his own, has been verified to comply with the local environment of the "reasonable installation of seam solution".

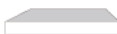
Great Wall cladding installation instructions (Wooden joist vertical installation)

Great Wall plate profile table

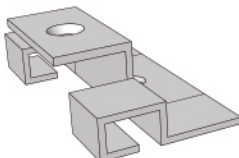
Product Name	Model	Material	Diagram	Specification(mm)	Uses
Great Wall cladding	HLYC-018F	Wood Plastic		155*24	Flat Decoration
Internal corner edge board	HLYC-020F	Wood Plastic		78*33.5	Great Wall cladding vertical installation internal corner board Start decoration
Edge board	HLYC-019F	Wood Plastic		69*90	Great Wall cladding vertical installation edge board Start decoration
External corner edge board	HLYC-021F	Wood Plastic		88.5*88.5	Great Wall cladding vertical installation external corner board decoration
I-shape edge board	HLYC-013F	Wood Plastic		89*38.5	patchwork decoration
Decorative cladding	HLSC-022B	Wood Plastic		18*184	Window and door openings

Great Wall Cladding Accessories List

Product Name	Model	Material	Diagram	Specification(mm)	Uses
Connecting accessories	HLPM-103(B)	304 stainless steel		50*28.4*13.9	Board joining accessories
Accessory Screws	HLPM-102(B)	304 stainless steel		M5-48	This screw is used for accessory fixing
Accessory Screws	HLPM-101(B)	304 stainless steel		M4-45	This screw is used for accessory locking board nails
Colored screws	HLPM-097(B)	304 stainless steel		M5-48	This screw is used for HLYC-018F, HLYC-019F HLYC-020F, HLYC-021F

Caution:

1. If you need to use other materials that are not in the accessory list during construction, please consult the product installation after-sales staff in advance.
2. All edge claddings and wall claddings fixed with open nails must be pre-drilled first, and then installed with screws. Screw center spacing is not more than 400mm. When the length of edge board and wall board is less than 400mm, the screws should be fixed with no less than 2 pieces.

Diagram of installation

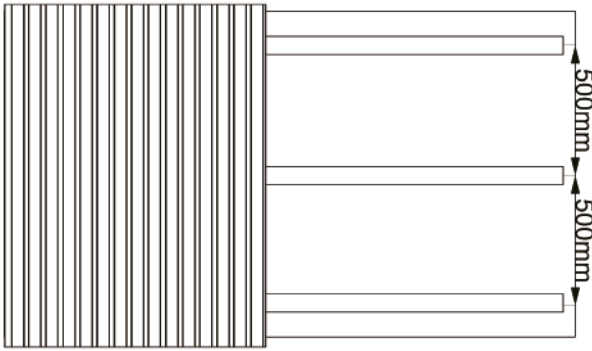

Horizontal arrangement

Caution:

1. To ensure effective drainage and ventilation of the wall cladding and wall foundation layer, the thickness of the joist must not be less than 50 mm, and this set of installation instructions takes a thickness of 50 mm as an example.
2. The distance between centers shall not be greater than 500 mm.

Accessory installation schematic

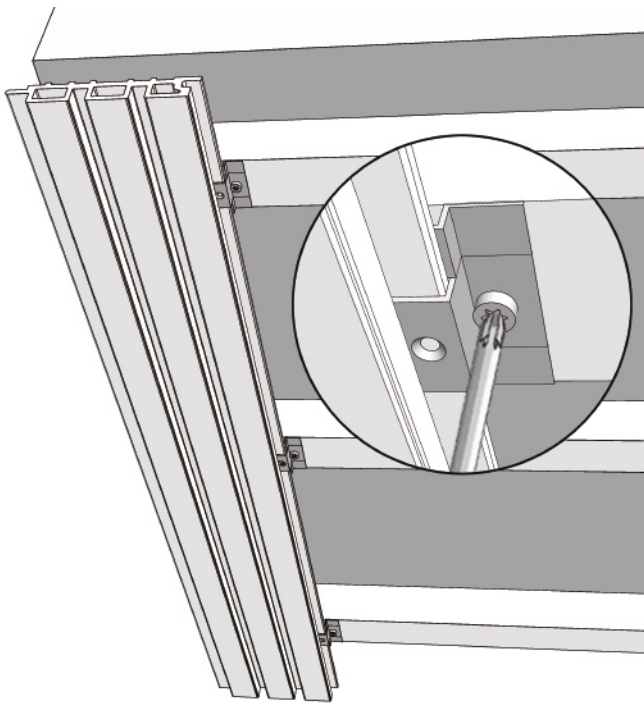

Accessory installation schematic

Caution:

1. Fittings must be arranged one for each joist, and the spacing in the direction of the length of the fixed wall cladding must not be greater than 500mm /piece.
2. When the fitting fixes the wall cladding, each wall cladding must have a locking board nail, the locking board nail position is determined according to the actual board thermal expansion and contraction, generally in the middle of the length of the wall cladding. As shown in the figure below:

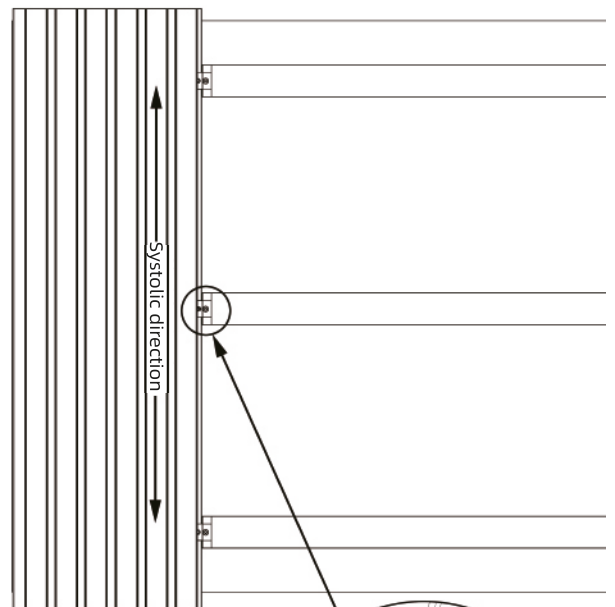

Locking board nails

Locking board nail
thermal expansion and contraction diagram

Caution:

If the length direction of the wall cladding exceeds that of a single board, the middle connection is recommended to use I-shape edge board.

wall cladding vertical installation schematic steps

Installation joist of wall cladding

Schematic diagram of the foundation layer of the Great Wall cladding installation.

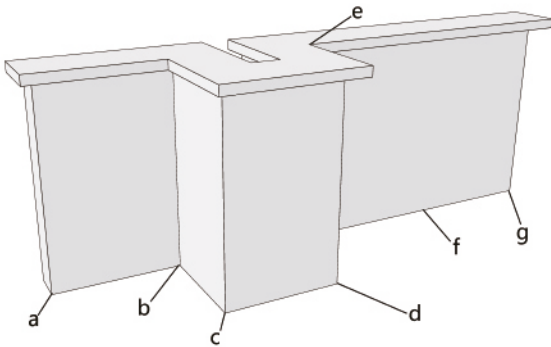

Schematic diagram of the base layer

Caution:

The levelness of the foundation layer of the Great Wall cladding installation must be flat.

Joist installation

1. Install joist of HLYC-019F, HLYC-020F, HLYC-021F. As shown in Figure 18-1:

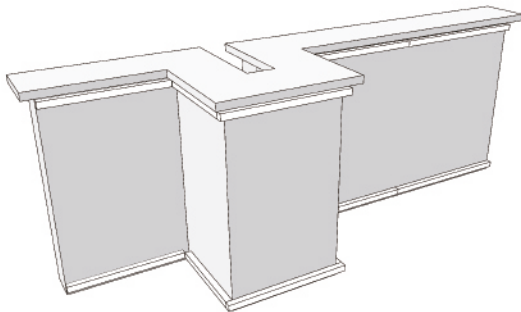

Fig18-1

2. Install the middle according to the center distance requirement. As shown in Figure 18-2:

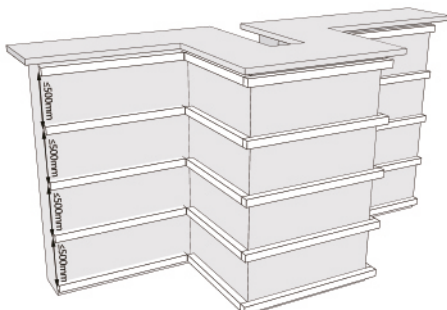

Fig18-2

HLYC-021F Installation

1. install the HLYC-021F. as shown in Figure 19:

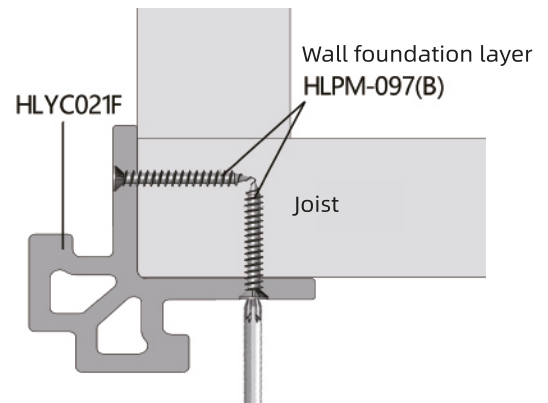

Fig19

HLYC-019F Installation

1. install the HLYC-019F. as shown in Figure 20:

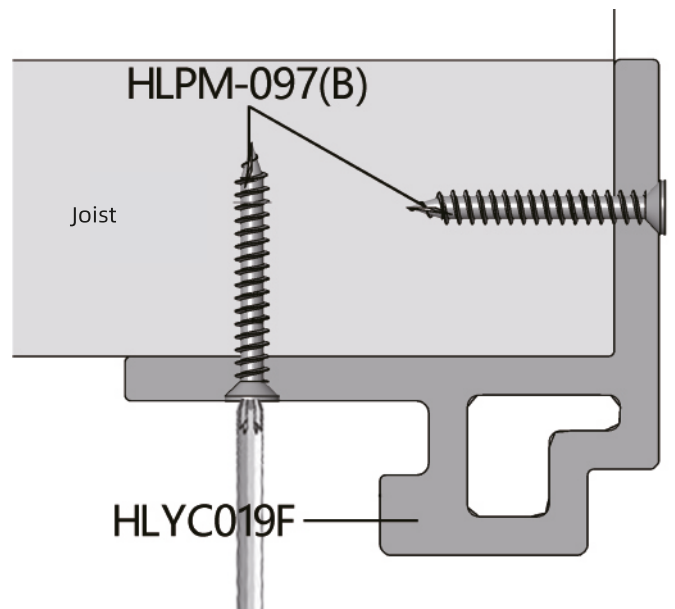

Fig20

HLYC-020F Installation

1. Install the HLYC-020F. as shown in Figure 21:

Great Wall cladding installation instructions (Wooden joist vertical installation)

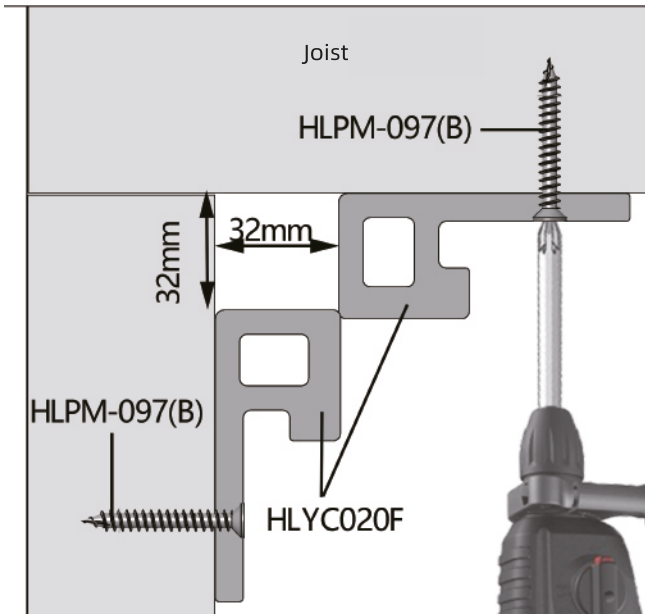

Fig21

Installation effect of HLYC-019F, HLYC-020F, HLYC-021F .As shown in Figure 22.

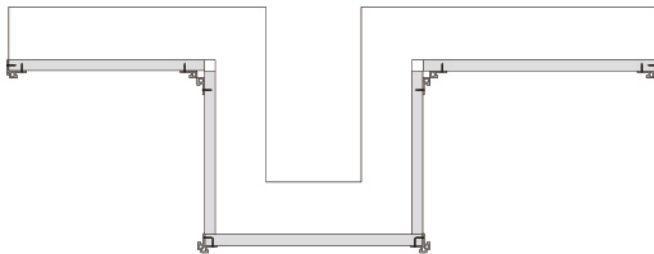

Fig22

Great Wall cladding Installation

Warm Tips:

To ensure the overall installation effect is beautiful, it is recommended that the first choice is to start from HLYC-021F, the second choice is to start from HLYC-019F. Try to ensure that the last edge board that needs to be cut is at HLYC-020F.

1. To install the Great Wall board, snap the board into the HLYC-021F or HLYC-019F slot, and then secure it with accessories at the end. As shown in Figures 23-1 and 23-2:

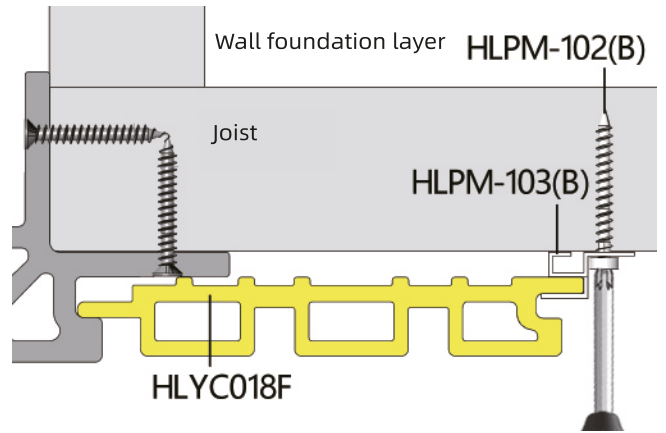

Fig23-1

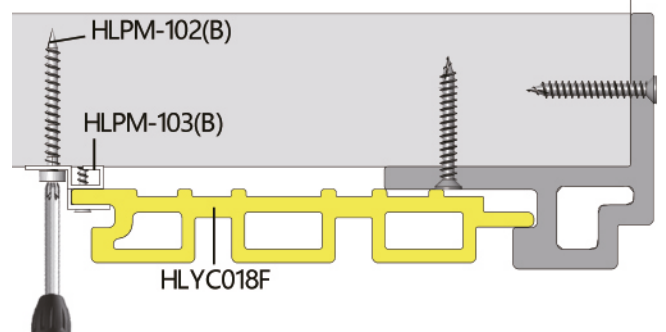

Fig23-2

2. According to the actual situation on site to determine the direction of thermal expansion and contraction of the wall cladding, such as the top and bottom of the wall cladding can be retracted, the locking board nails fixed in the middle of the board position. As shown in Figure 23-3 and 23-4:

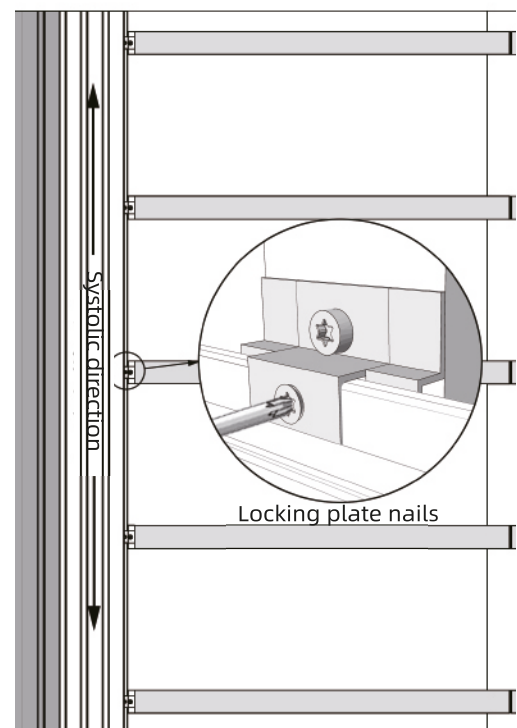

Fig23-3

Great Wall cladding installation instructions (Wooden joist vertical installation)

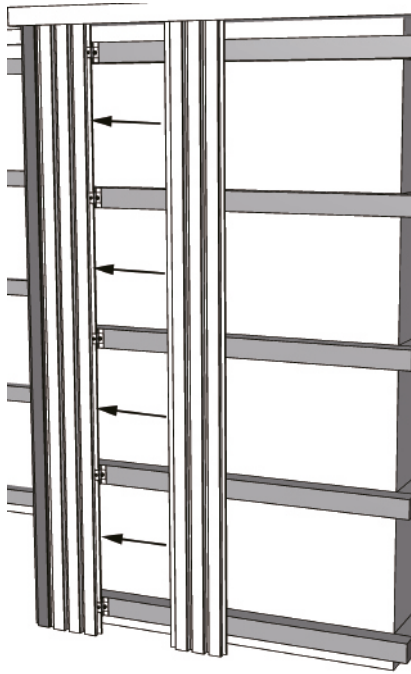

Fig23-4

3. Follow the steps in Figure 23-4 to install to the most side board. As shown in Figure 23-5.

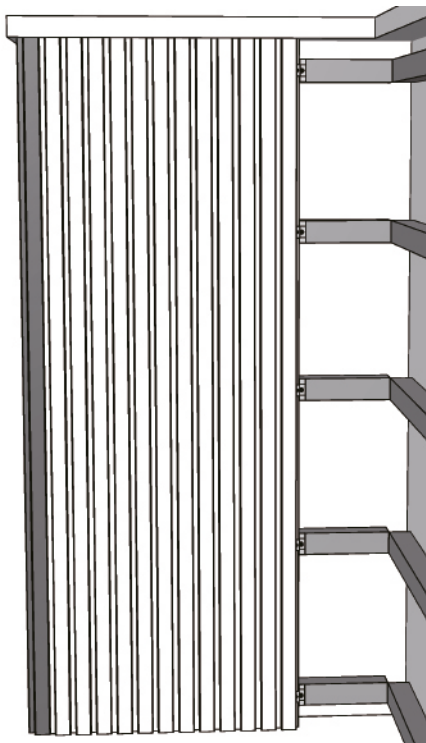

Fig23-5

4. Install the final wall cladding , cut the wall cladding according to the site to determine the size and then install it. As shown in Figures 23-6 and 23-7:

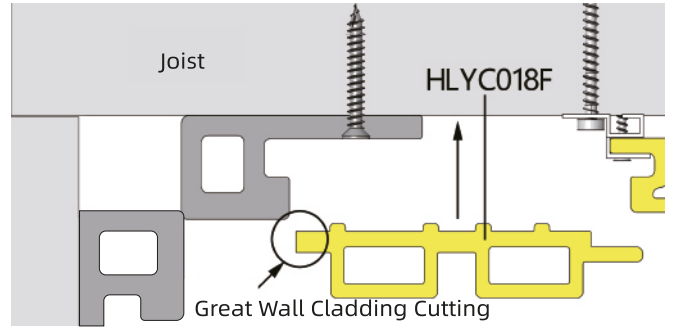

Fig23-6

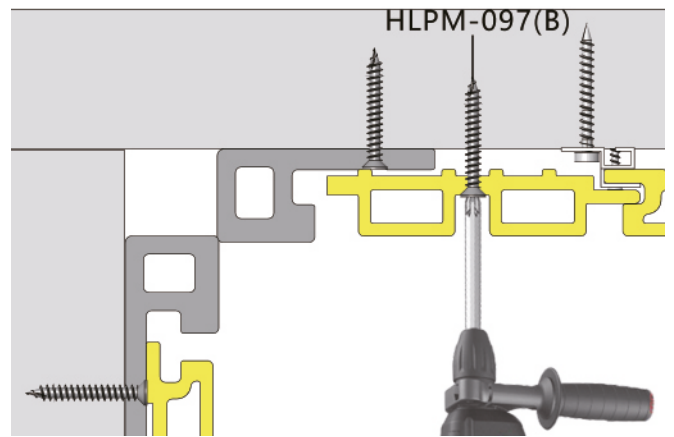

Fig23-7

Great Wall cladding vertical splicing installation effect.As shown in Figure 24.



Fig24

Great Wall cladding vertical installation special case installation reference

1.Vertical installation of the Great Wall cladding requires the base of 2 pieces when installed. As shown in Figure E and F:

Figure E Notes for installation:

Great Wall claddings need to be spliced with a 2mm thermal expansion and contraction gap, and each board a locking nail fixed in the splice.

Great Wall cladding installation instructions (Wooden joist vertical installation)

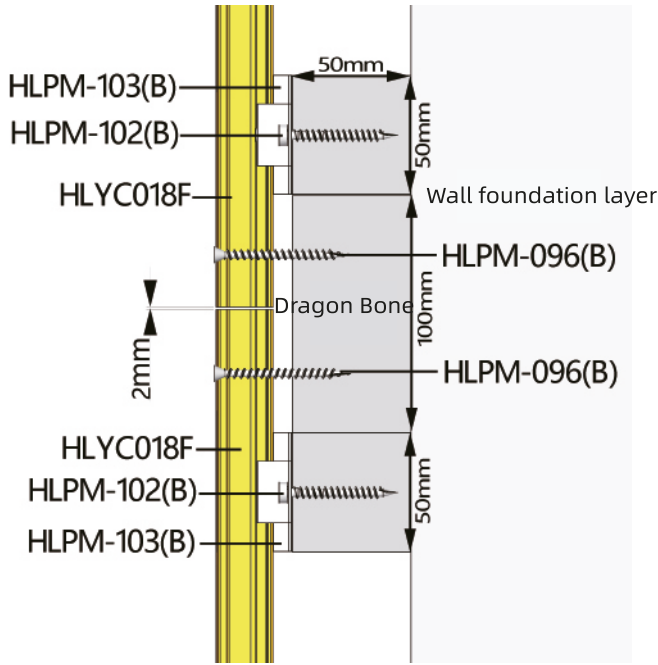

FigE

Notes for Figure F installation:

When installing HLYC-013F, leave a gap according to the thermal linear expansion coefficient.

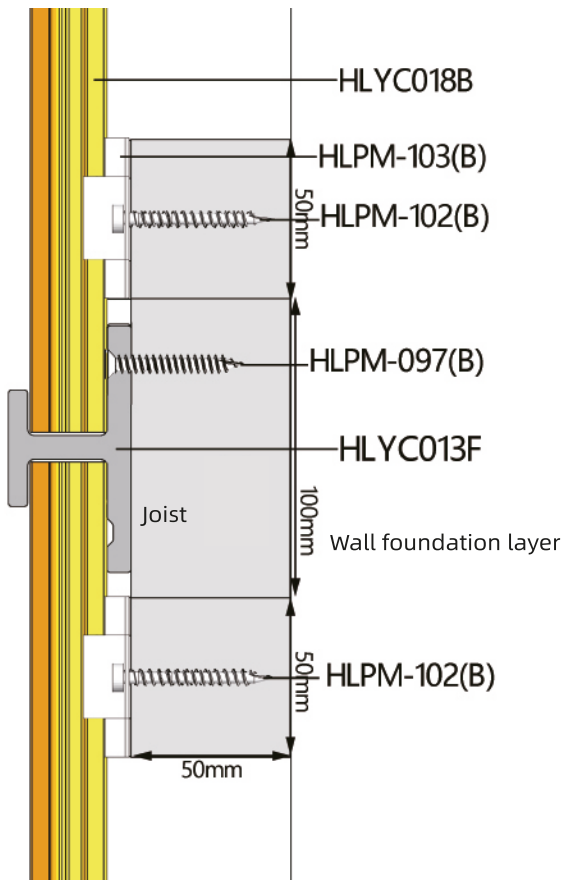

FigF

2. When more than 2 boards are installed, it is recommended to arrange the reasonable position of each wall cladding locking nail according to the actual situation on site and combined with the thermal linear expansion coefficient.

Installation of window and door openings

Diagram of general window and door openings.

Caution:

HLYC-019F installation completed, install the joists around.

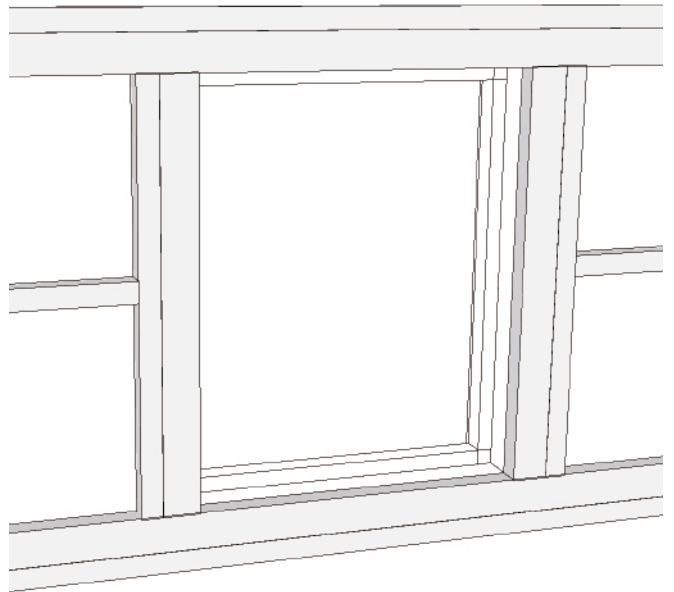

Diagram of window openings

1. Determine the size and cut HLYC-019F according to the size of the door and window openings. As shown in Figure 24-1

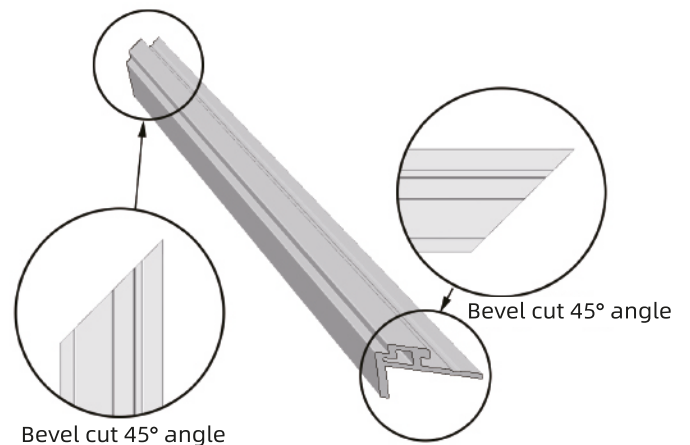

Fig24-1

Great Wall cladding installation instructions (Wooden joist vertical installation)

2. Door and window openings HLYC-019F (45 degree angle to spell), pre-drilled holes and then fixed with open nails. As shown in Figure 24-2:

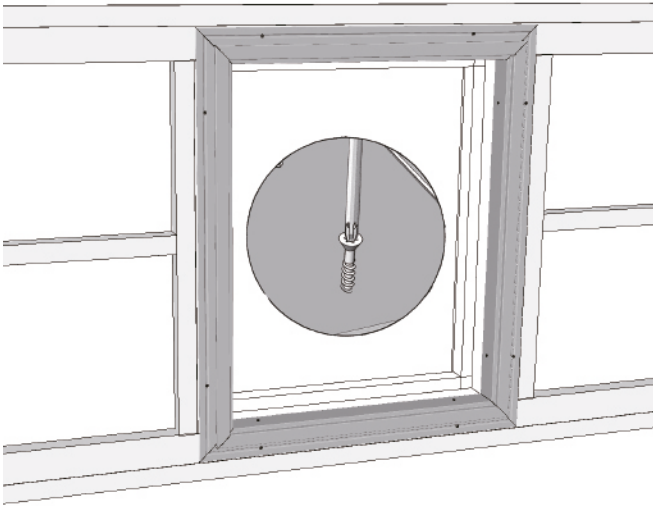

Fig24-2

3..Complete the installation of the wall cladding together with the normal large wall surface.As shown in Figure 24-3:

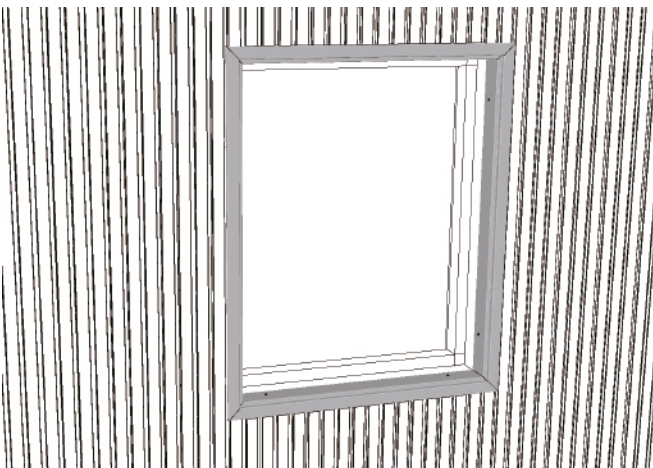

Fig24-3

4. Determine the size and cut HLSC-022B according to the size of the window and door openings. As shown in Figure 24-4:

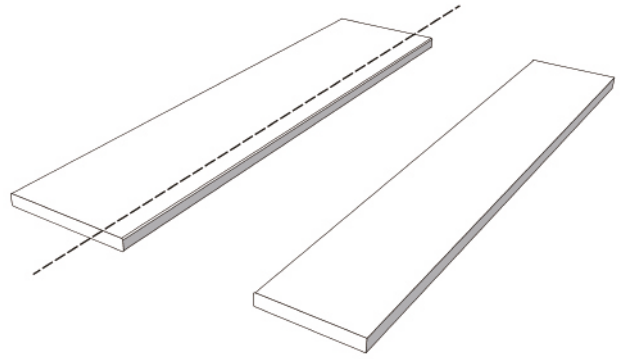

Fig24-4

5.Install the board cut in the previous step,pre-drilled holes and then fixed with open nails.As shown in Figure 24-5:

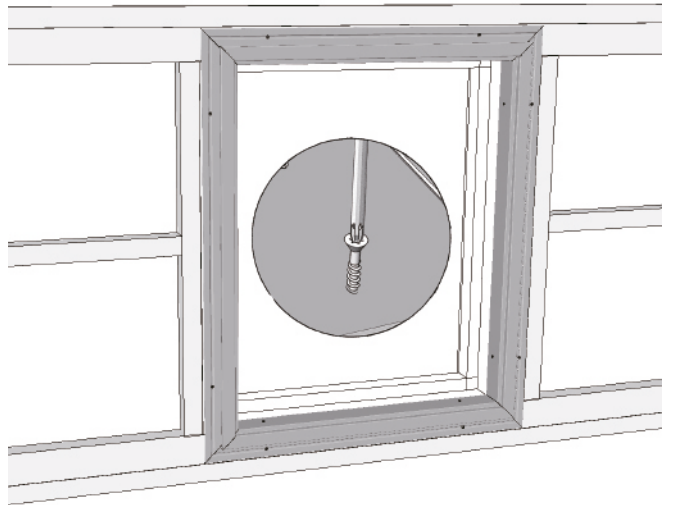

Fig24-5